

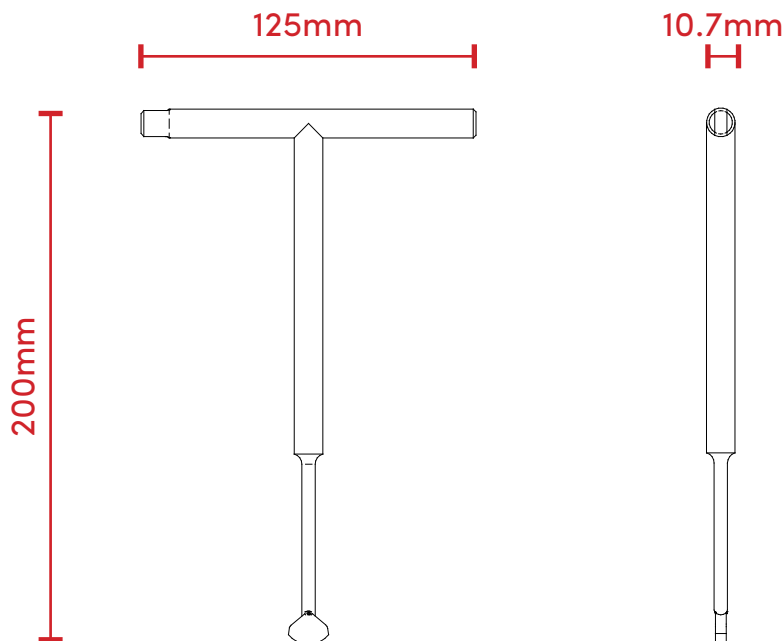

DATA SHEET ADJUSTING KEY FOR SUPPORTS



TECHNICAL SPECIFICATION

The "Pedestal" paving supports, offer multiple solutions to compensate for small imperfections and large gradients of any laying surface so as to always achieve a very stable and perfectly flat floor.

The unique adjustment key, an essential element of the system also allows the control of the paver supports (and consequently the floor above) even with a finished floor thus avoiding having to lift the tile.

RAW MATERIAL:

Steel 45CrMoS4
Powder painting RAL3000

ENVIRONMENTAL IMPACT:

recyclable material - not dangerous

ADVANTAGES:

Quick and precise adjustment of the supports by hand
Adjustment of the supports, even with finished flooring
Easy removal of tabs from Eternoivica heads

FIELD OF USE (ASSOCIATED SUPPORT):

Accessory for Pedestal supports

GENERAL CHARACTERISTICS & PROPERTIES

Cod:E200250120	UNIT	VALUE	TOLERANCE +/-
Adjustment key DIMENSION	mm	200x125x10.7	+/- 0.2
Adjustment key WEIGHT	Kg	0.185	+/- 0.01
Adjustment plate THICKNESS	mm	4	+/- 0.2
HARDNESS	HRB	85	+/- 1

PACKAGING: The adjustment key is sold individually

The above data are relevant to current production and may be changed or updated by Eterno Ivica at any time without notice. Given the many possible uses and the possible interference of external elements, we do not assume responsibility for the results. The buyer is required to establish under their own responsibility the suitability of the product for the intended use. This document is property of Eterno Ivica. All rights reserved.